



SWE12180 (12V18AH)



Specifications

Nominal Voltage		12V
Rated capacity (20hour rate)		18Ah
Dimensions	Total Height	167 mm (6.57 inches)
	Height	167 mm (6.57 inches)
	Length	181 mm (7.13 inches)
	Width	77 mm (3.03 inches)
Weight Approx		5.3Kg (11.7lbs)

Characteristics

Capacity 25°C(77°F)	20 hour rate(0.9A)	18.0 AH
	10 hour rate(1.65A)	16.5AH
	5 hour rate(2.88A)	14.4AH
	1 hour rate(9.90A)	9.90AH
	1.5 hour discharge to 10.5V	6.8 A
Internal Resistance	Full charged Battery at 25°C(77°F)	10m Ω
Capacity affected by Temperature (20hour rate)	40°C(104°F)	102%
	25°C(77°F)	100%
	0°C(32°F)	85%
	-15°C(5°F)	65%
Self-Discharge at 25°C(77°F)	Capacity after 3 month storage	91%
	Capacity after 6 month storage	82%
	Capacity after 12 month storage	64%
Terminal	T3, T13	
Charge (constant Voltage)	Cycle	Initial Charging Current less than 4.50A Voltage 14.10-14.40V
	Float	Voltage 13.50-13.80V

Outer dimensions (mm)

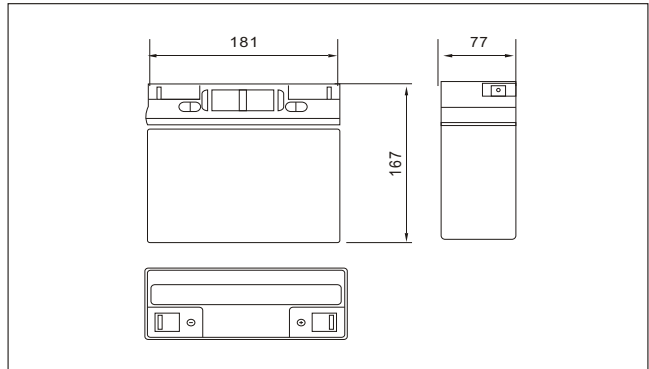

Terminal Type (mm)

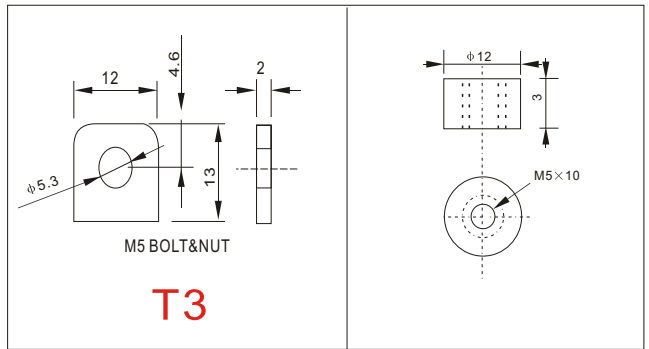

Discharge Curves 25°C(77°F)

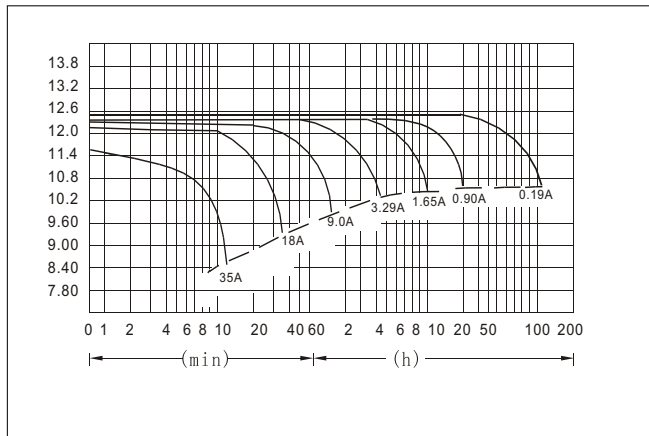

Constant Current(Amp) and Constant Power(Watt) Discharge Table at 25°C(77°F)

Time		10min	30min	1h	3h	4h	5h	8h	10h	20h	50h	100h
9.60V	A	35	19	10	4.2	3.29	2.72	1.92	1.73	0.93	0.39	0.20
	W	386	201	114	49	38	31	22	20	10.8	4.6	2.4
10.20V	A	34	18	9.3	4.1	3.21	2.67	1.87	1.69	0.91	0.38	0.194
	W	371	199	108	48	37	31	22	20	10.5	4.5	2.3
10.50V	A	32	17.4	9	4.0	3.16	2.64	1.86	1.65	0.90	0.37	0.189
	W	360	188	104	47	37	31	22	19	10.4	4.4	2.3
10.80V	A	30	16.8	9	3.9	3.1	2.57	1.81	1.61	0.89	0.36	0.188
	W	346	181	100	46	36	30	21	19	10.4	4.3	2.2
11.10V	A	28	15	8	3.8	3.0	2.50	1.76	1.56	0.84	0.36	0.181
	W	340	180	97	45	36	30	21	19	10.1	4.2	2.2